

BAG OPENER



The Machinex bag opener is an essential equipment when comes the time to process material that is totally or partially bagged. Located at the front end of the system, it can be integrated in-line when all material is bagged, or as a backup unit on which only bagged material is diverted. Its two rotating blade shears the plastic bags, liberating material without damaging the recyclables.

MODEL

	Opening Dimensions	Overall Dimensions
Bag Opener	66" x 48" (1676 mm x 1229 mm)	96" W x 10' L x 60" H (2438 mm x 254 mm x 1524 mm)

BENEFITS

- ▶ Dual counter-rotating blade shear the bags and liberate material without damaging it
- ▶ Easy in-line or manually fed integration
- ▶ Capacity over 30 TPH of MSW & yard waste
- ▶ Capacity of 15 to 20 TPH on recyclables

APPLICATIONS

- ▶ Single-Stream
- ▶ Commingled Plastic
- ▶ Municipal Solid Waste
- ▶ Commercial Waste

Bag opener

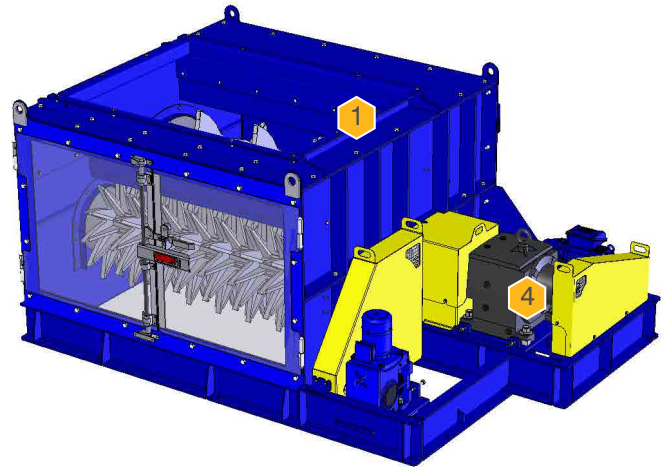
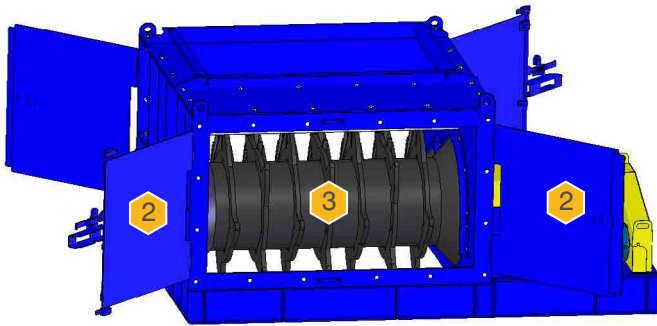

CONSTRUCTION & FEATURES (REFER TO 3D DRAWING)

- ▶ 1 Heavy duty frame construction
- ▶ 2 Access doors on both side for maintenance
- ▶ 3 Bag opening drums with anti-blocking features
- ▶ 4 Two motors setup: 2 and 20 HP
- ▶ Weight of 13 810 livres (6250 kg)
- ▶ Variable frequency drive
- ▶ Complete electrical control package available



Shear blade tips hardened for extended life and less maintenance cost